



KSD-SA25.2-XXXMJ

(Based on MLC NAND Flash 2.5" SATA+USB SSD)

Datasheet

Rev.1.2

Jan. 2009



NOTE: INFORMATION IN THIS PRODUCT SPECIFICATION IS SUBJECT TO CHANGE AT ANYTIME WITHOUT NOTICE, ALL PRODUCT SPECIFICATIONS ARE PROVIDED FOR REFERENCE ONLY. TO ANY INTELLECTUAL PROPERTY RIGHTS IN KINGSPEC PRODUCT OR TECHNOLOGY. ALL INFORMATION IN THIS DOCUMENT IS PROVIDED.



Table of Contents

A.	Introduction.....	3
B.	Block Diagram.....	4
C.	Product Specifications.....	5
	1. Physical Specifications.....	5
	2. Interface.....	5
	3. Performance.....	6
D.	Interface Description	7
	1. Pin Assignment.....	7
	2. Pin Description.....	7
E.	Product Trait.....	8
	1. Environment Specification.....	8
	2. Power Specification.....	8
	3. Reliability Specification.....	9
F.	Electrical Specification.....	10
G.	Command Description.....	11
H.	Ordering Information.....	15



A. Introduction

1. Overview

Kingspec's SATA SSD (Solid State Drive) is a high performance and high reliability storage device based on NAND Flash technology that designed to solve the bottleneck of computing system by traditional hard disk drives. Kingspec's SATA SSD doesn't have a moving parts and it has a same host interface and same physical dimension with Hard Disk Drive, So it can be drop-in replaced with the hard disk drives without anything. With a high performance and low power consumption, Kingspec's SATA SSD can be a good storage device for NB and Tabletop PC ,

Kingspec's SATA SSD purely consists of semiconductor devices and NAND flash memories, which give rugged features against shock and vibration use in extreme environment such as industrial PC an increased MTBF. Further more, Kingspec's SATA SSD has highly advanced flash memory management algorithm to guarantee higher performance and data integrity.

2. Feature

- Performance

SATA: External Transfer Rate(Host Transfer Rate):300MB/s

Sequential Data Read/Write:	110/37 MB/s(8GB)	120/58 MB/s(16GB)
	110/59 MB/s(20GB)	155/89 MB/s(32GB)
	110/58 MB/s(40GB)	140/89 MB/s(64GB)
	105/58 MB/s(80GB)	144/90 MB/s(128GB)
	108/58 MB/s(160GB)	140/90 MB/s(256GB)

USB: External Transfer Rate(Host Transfer Rate):60MB/s

Sequential Data Read/Write: 35/25 MB/s

- Form factor: 2.5-inch (100.0mm x 69.7mm x 9.1mm)
- Interface standard: Serial ATA Revision 2.6 and Universal Serial Bus Specification Revision 2.0
- Density: 8GB,16GB, 20GB,32GB,40GB,64GB,80GB,128GB,160GB,256GB
- Input voltage: 5V (±5%)
- Commercial operating temperature range form 0 to +70°C
- Flash management algorithm: static and dynamic wear-leveling, bad block management algorithm
- Supports dynamic power management and SMART (Self-Monitoring, Analysis and Reporting Technology)
- ECC (Error Correction Code): BCH ECC 8bits or 15bits in 512Bytes
- Write endurance: >8 years @ 100GB write/ day(32GB)
- Read endurance: unlimited
- Data retention: 10 years
- MTBF:1,000,000 Hours

B. Block Diagram

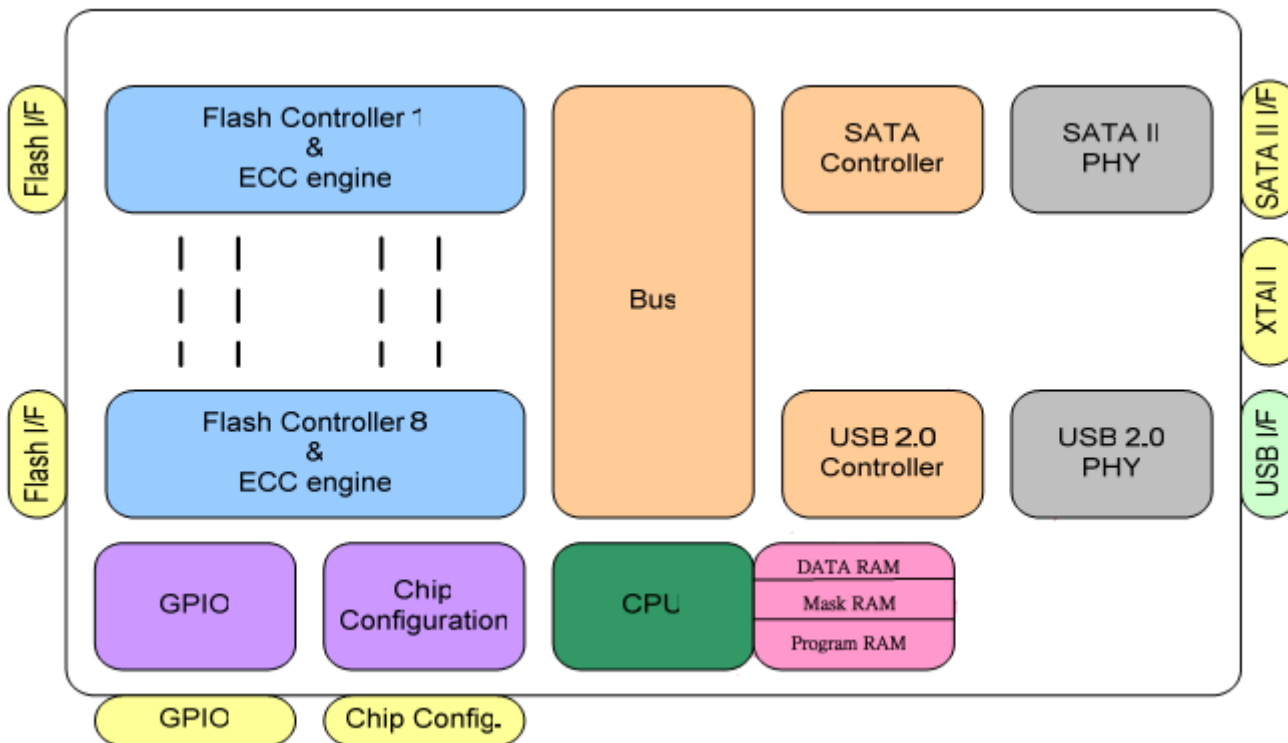

C. Product Specifications

ADD:501#, Pioneering Park, University Town, LiShan Rd., Nanshan, Shenzhen, P.R. China

Tel:+86 0755-2698 5376 Fax:+86 0755-2698 5365

Website: www.kingspec.com



1.Physical Specifications

Tabel 1 Physical dimensions and weight

Model	Height (mm)	Width (mm)	Length (mm)	Weight(g)
8GB~256GB	9.1+/-0.15	69.7+/-0.15	100.0+/-0.15	TBD

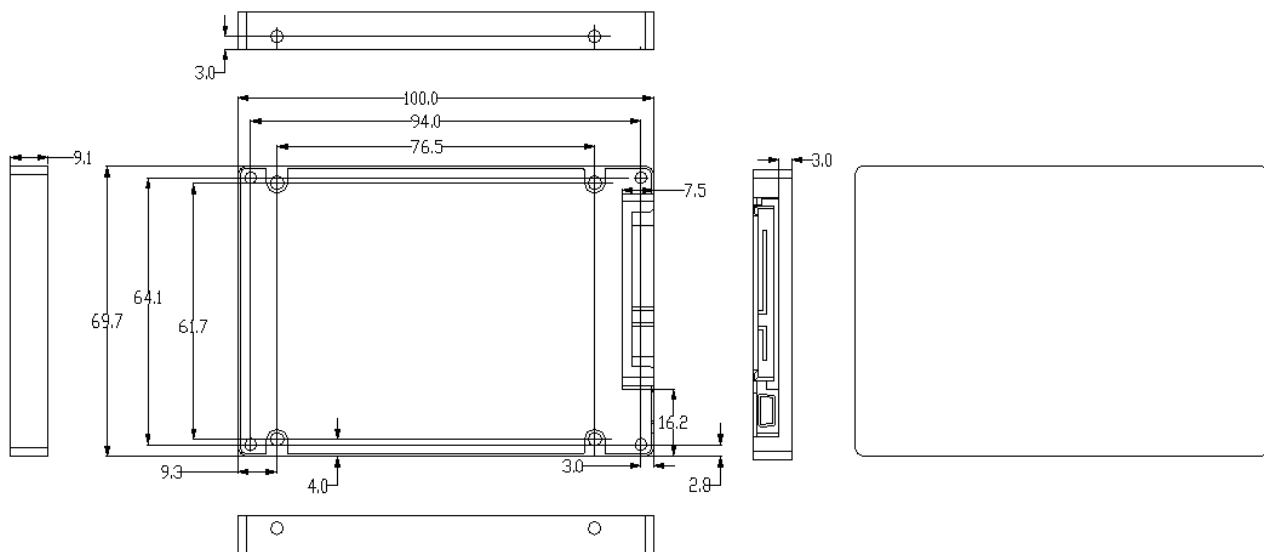

2.Interface

The interface of Kingspec's SSD complies with the standard serial ATA revision 2.6 and Universal Serial Bus Specification Revision 2.0:

- ①SATA Host Transfer Rate is 300MB/s(3.0Gb/s)
- ②USB Host Transfer Rate is 60MB/s(480Mb/s)
- ③PIO mode 0,1,2,3,4
- ④DMA mode 0,1,2
- ⑤UDMA mode 0,1,2,3,4,5,6

3.Performance Testing

3.1 Maximum Data Transfer Rate:

ADD:501#, Pioneering Park, University Town, LiShan Rd., Nanshan, Shenzhen, P.R. China

Tel:+86 0755-2698 5376 Fax:+86 0755-2698 5365

Website: www.kingspec.com



SATA:·Maximum sustained read: 155MB/s
·Maximum sustained write: 89MB/s
USB: ·Maximum sustained read: 35MB/s
·Maximum sustained write: 25MB/s

Note:

- 1) .Test PC:AMD Athlon 64 3000+ 1.8GHz, DDR2 PC2-5300 512MB×2pcs double channel. RAM, NVIDIA nForce520 chipset, Microsoft Windows XP Professional SP3
- 2) .Test Program: HDBench3.4.0.3
- 3) .Test Drive: KSD-SA25.2-032MJ(MLC)

3.2 IO Performance:

Tabel 2 IO Performance Values For 2.5" SATA MLC SSD

Access Type	IOPS	
	Operation unit size	
	512Byte	4KByte
Sequential Read	6109	5217
Sequential Write	9122	5142
Random Read	6100	4515
Random Write	16	15

Note:

- 1) .Test PC:AMD Athlon 64 3000+ 1.8GHz, DDR2 PC2-5300 512MB×2pcs double channel. RAM, NVIDIA nForce520 chipset, Microsoft Windows XP Professional SP3
- 2) .Test Program: IOMeter 2006.07.27
- 3) .Test Drive: KSD-SA25.2-032MJ(MLC)

3.3 Access Time:

Random access time: 0.2 msec

Note:

- 1) .Test PC:AMD Athlon 64 3000+ 1.8GHz, DDR2 PC2-5300 512MB×2pcs double channel. RAM, NVIDIA nForce520 chipset, Microsoft Windows XP Professional SP3
- 2) .Test Program: HDTech 3.0.1
- 3) .Test Drive: KSD-SA25.2-032MJ(MLC)

D. Interface Description

ADD:501#, Pioneering Park, University Town, LiShan Rd., Nanshan, Shenzhen, P.R. China

Tel:+86 0755-2698 5376 Fax:+86 0755-2698 5365

Website: www.kingspec.com

1. SATA Pin Assignment

The following diagram identifies the pin location of Kingspec SATA SSD.

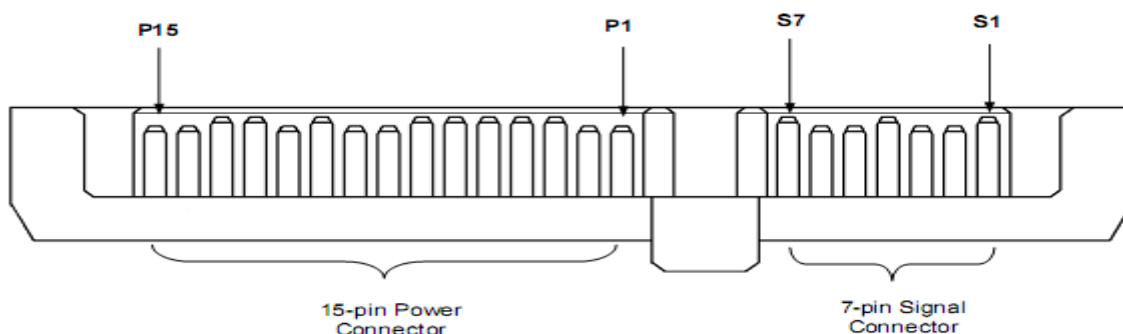

2. SATA Pin Description

Tabel 3 SATA Connector Pinout Signal

Pin#	Signal Name	Description
S1	GND	2 nd mate
S2	A+	Differential signal pair A From physical layer electronics
S3	A-	
S4	GND	2 nd mate
S5	B-	Differential signal pair B From physical layer electronics
S6	B+	
S7	GND	2 nd mate
Power		
P1	V33	3.3V Power(Unused)
P2	V33	3.3V Power(Unused)
P3	V33	3.3V Power,pre-charge, 2 nd mate(Unused)
P4	GND	1 st mate
P5	GND	2 nd mate
P6	GND	2 nd mate
P7	V5	5V Power,pre-charge, 2 nd mate
P8	V5	5V Power
P9	V5	5V Power
P10	GND	2 nd mate
P11	DAS/DSS	Device Activity Signal/Disable Staggered spinup(Unused)
P12	GND	1 st mate
P13	V12	12V Power,pre-charge, 2 nd mate(Unused)
P14	V12	12V Power(Unused)
P15	V12	12V Power(Unused)

3.miniUSB Pin Assignment

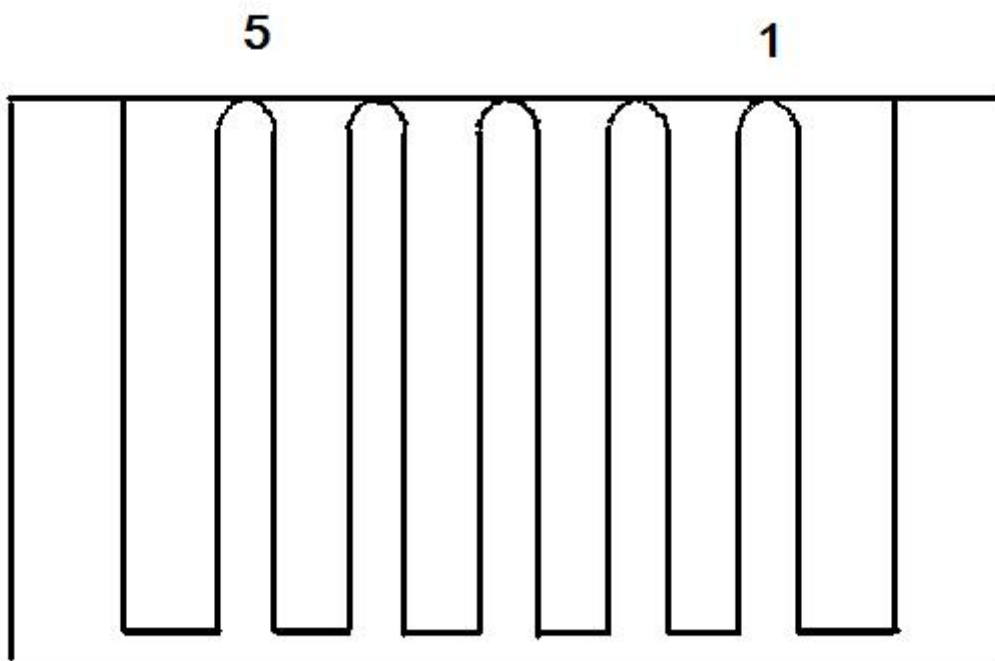

4.miniUSB Pin Description

Tabel 4 miniUSB Connector Pinout

Pin#	Signal Name	Description
1	V5	USB 5V Power
2	D-	USB 2.0 Differential pair
3	D+	
4	GND	Ground for power return
5	GND	Ground for power return

E.Product Trait

1. Environment Specification

ADD:501#, Pioneering Park, University Town, LiShan Rd., Nanshan, Shenzhen, P.R. China

Tel:+86 0755-2698 5376 Fax:+86 0755-2698 5365

Website: www.kingspec.com



Table 4 Environmental Specifications

Features	Operating	Non-operating
Temperature	0~70℃	-45~95℃
Humidity	5-95%	
Vibration	20G(40-2000HZ)	
Shock	2,000G(@0.3ms half sine wave)	

2.Power Specification

Recommended DC Operating Voltage:4.75V~5.25V

Table 5 Power Consumption

Parameter		Typical	Unit
Standby		0.5	W
Idel		0.5	W
4KByte Sample Data	Sequential Read	1.15	W
	Sequential Write	1.0	W
	Random Read	2.0	W
	Random Write	2.0	W
512KByte Sample Data	Sequential Read	1.15	W
	Sequential Write	1.3	W
	Random Read	2.0	W
	Random Write	2.0	W

Note:

1. The power consumption can differ depending on the disk capacity and the type of flash memory being used
2. The test drive:KSD-SA25.2-128MJ
3. Supply voltage:5.0V+/-5%

3. Reliability Specification

Wear-leveling

ADD:501#, Pioneering Park, University Town, LiShan Rd., Nanshan, Shenzhen, P.R. China

Tel:+86 0755-2698 5376 Fax:+86 0755-2698 5365

Website: www.kingspec.com



Kingspec's SSD support both static and dynamic wear-leveling, These two algorithms guarantee all type of flash memory at same level of erase cycles to improve lifetime limitation of NAND based storage

Endurance

Write endurance: >8 years @ 100GB write/ day(32GB)

Read endurance: unlimited

ECC

ECC (Error Correction Code): BCH ECC 8bits or 15bits in 512Bytes

Bad block management algorithm

This algorithm replaces bad blocks with new ones from available spares on media error conditions.

MTBF

MTBF(Mean Time between Failures) of Kingspec's SSD: 1, 000, 000 hours

Data retention

Data retention at 25°C of Kingspec's SSD:>10 years

F. Electrical Specification

Absolute Maximum Rating

Parameter	Symbol	Condition	Min	Max	Unit
Analog power supply	AVDDH		-0.5	6	V
Digital I/O power supply	DVDD		-0.5	6	V
Digital I/O input voltage	V _{I(D)}		-0.4	DVDD+0.4	V
Storage temperature	T _{STORAGE}		-55	140	°C

Recommended Power Supply Operation Conditions

Parameter	Symbol	Condition	Min	Typical	Max	Unit
Operation digital power supply	PV33		3.0	3.3	3.6	V
	D1V8		1.85	1.9	2.0	V
Operation analog power supply	ASV33		3.0	3.3	3.6	V
	ASV18		1.85	1.9	2.0	V
	AVDDH		3.0	3.3	3.6	V
Ambient operation temperature	T _A	For commercial spec.	0		70	°C
Ambient operation temperature	T _A	For industry spec.	-40		85	°C
Junction temperature	T _J		0		125	°C

Recommended External Clock Source Conditions

Parameter	Symbol	Condition	Min	Typical	Max	Unit
External reference clock				30		MHz
Clock Duty Cycle			45	50	55	%

I/O DC Characteristics

Parameter	Symbol	Condition	Min	Typical	Max	Unit
Input low voltage	V _{IL}				0.8	V
Input high voltage	V _{IH}		2.0			V
Output low voltage	V _{OL}		0		0.4	V
Output high voltage	V _{OH}		2.6		3.6	V

G.Command Descriptions

Support ATA Command

ADD:501#, Pioneering Park, University Town, LiShan Rd., Nanshan, Shenzhen, P.R. China

Tel:+86 0755-2698 5376 Fax:+86 0755-2698 5365

Website: www.kingspec.com



Command Name	Code (Hex)	Command Name	Code (Hex)
CHECK POWER MODE	E5h	SECURITY ERASE UNIT	F4h
EXECUTE DIAGNOSTICS	90h	SECURITY FREEZE LOCK	F5h
FLUSH CACHE	E7h	SECURITY SET PASSWORD	F1h
IDENTIFY DEVICE	ECh	SECURITY UNLOCK	F2h
IDLE	E3h	SEEK	7xh
IDLE IMMEDIATE	E1h	SET FEATURES	EFh
INITIALIZE DEVICE PARAMETERS	91h	SET MULTIPLE MODE	C6h
READ DMA	C8h or C9h	SLEEP	E6h
READ MULTIPLE	C4h	SMART	B0h
READ SECTOR(S)	20h or 21h	STANDBY	E2h
READ VERIFY SECTOR(S)	40h or 41h	STANDBY IMMEDIATE	E0h
RECALIBRATE	10h	WRITE DMA	CAh or CBh
SECURITY DISABLE PASSWORD	F6h	WRITE MULTIPLE	C5h
SECURITY ERASE PREPARE	F3h	WRITE SECTOR(S)	30h or 31h

ATA COMMAND SPECIFICATIONS

CHECK POWER MODE (E5h)

The host can use this command to determine the current power management mode.

EXECUTE DIAGNOSTICS (90h)

This command performs the internal diagnostic tests implemented by the drive. See ERROR register for diagnostic codes.

FLUSH CACHE (E7h)

This command is used by the host to request the device to flush the write cache. If there is data in the write cache, that data shall be written to the media. The BSY bit shall remain set to one until all data has been successfully written or an error occurs.

IDENTIFY DEVICE (ECh)

This commands read out 512Bytes of drive parameter information. Parameter Information consists of the arrangement and value as shown in the following table. This command enables the host to receive the Identify Drive Information from the device.

IDLE (E3h)

This command causes the device to set BSY, enter the Idle mode, clear BSY and generate an interrupt. If sector count is non-zero, the automatic power down mode is enabled. If the sector count is zero, the automatic power mode is disabled.

IDLE IMMEDIATE (E1h)

This command causes the device to set BSY, enter the Idle(Read) mode, clear BSY and generate an interrupt.

ADD:501#, Pioneering Park, University Town, LiShan Rd., Nanshan, Shenzhen, P.R. China

Tel:+86 0755-2698 5376 Fax:+86 0755-2698 5365

Website: www.kingspec.com



INITIALIZE DEVICE PARAMETERS (91h)

This command enables the host to set the number of sectors per track and the number of tracks per heads.

READ DMA (C8h)

Reads data from sectors during Ultra DMA and Multiword DMA transfer. Use the SET FEATURES command to specify the mode value. A sector count of zero requests 256 sectors.

READ MULTIPLE (C4h)

This command performs similarly to the Read Sectors command. Interrupts are not generated on each sector, but on the transfer of a block which contains the number of sectors defined by a Set Multiple command.

READ SECTOR(S) (20h/21h)

This command reads 1 to 256 sectors as specified in the Sector Count register from sectors which is set by Sector number register. A sector count of 0 requests 256 sectors. The transfer beings specified in the Sector Number register.

READ VERIFY SECTOR(S) (40h/41h)

This command verifies one or more sectors on the drive by transferring data from the flash media to the data buffer in the drive and verifying that the ECC is correct. This command is identical to the Read Sectors command, except that DRQ is never set and no data is transferred to the host.

RECALIBRATE (10h)

The current drive performs no processing if it receives this command. It is supported for backward compatibility with previous devices.

SECURITY DISABLE PASSWORD (F6h)

Disables any previously set user password and cancels the lock. The host transfers 512 bytes of data, as shown in the following table, to the drive. The transferred data contains a user or master password, which the drive compares with the saved password. If they match, the drive cancels the lock. The master password is still saved. It is re-enabled by issuing the SECURITY SET PASSWORD command to re-set a user password.

SECURITY ERASE PREPARE (F3h)

This command shall be issued immediately before the Security Erase Unit command to enable erasing and unlocking. This command prevents accidental loss of data on the drive.

SECURITY ERASE UNIT (F4h)

The host uses this command to transfer 512 bytes of data, as shown in the following table, to the drive. The transferred data contains a user or master password, which the drive compares with the saved password. If they match, the drive deletes user data, disables the user password, and cancels the lock. The master password is still saved. It is re-enabled by issuing the SECURITY SET PASSWORD command to re-set a user password.

SECURITY FREEZE LOCK (F5h)

Causes the drive to enter Frozen mode. Once this command has been executed, the following

ADD:501#, Pioneering Park, University Town, LiShan Rd., Nanshan, Shenzhen, P.R. China

Tel:+86 0755-2698 5376 Fax:+86 0755-2698 5365

Website: www.kingspec.com



commands to update a lock result in the

Aborted Command error:

- SECURITY SET PASSWORD
- SECURITY UNLOCK
- SECURITY DISABLE PASSWORD
- SECURITY ERASE PREPARE
- SECURITY ERASE UNIT

The drive exits from Frozen mode upon a power-off or hard reset. If the SECURITY FREEZE LOCK command is issued when the drive is placed in Frozen mode, the drive executes the command, staying in Frozen mode.

SECURITY SET PASSWORD (F1h)

This command set user password or master password. The host outputs sector data with PIO data-out protocol to indicate the information defined in the following table.

SECURITY UNLOCK (F2h)

This command disable LOCKED MODE of the device. This command transfers 512 bytes of data from the host with PIO data-out protocol. The following table defines the content of this information.

SEEK (7xh)

This command is effectively a NOP command to the device although it does perform a range check.

SET FEATURES (EFh)

This command set parameter to Features register and set drivelfls operation. For transfer mode, parameter is set to Sector Count register. This command is used by the host to establish or select certain features.

Features register Value and settable operating mode

Value	Function
02h	Enable write cache
03h	Set transfer mode based on value in Sector Count register.
55h	Disable read look-ahead feature
82h	Disable write cache
AAh	Enable read look-ahead feature

SET MULTIPLE MODE (C6h)

This command enables the device to perform READ MULTIPLE and WRITE MULTIPLE operations and establishes the block count for these commands.

SLEEP (E6h)

This command causes the device to set BSY, enter the Sleep mode, clear BSY and generate an interrupt.

SMART Function Set (B0h)

Performs different processing required for predicting device failures, according to the subcommand specified in the Features register. If the Features register contains an unsupported value,

ADD:501#, Pioneering Park, University Town, LiShan Rd., Nanshan, Shenzhen, P.R. China



the Aborted Command error is returned. If the SMART function is disabled, any subcommand other than SMART ENABLE OPERATIONS results in the Aborted Command error.

STANDBY (E2h)

This command causes the device to set BSY, enter the Sleep mode (which corresponds to the ATA!Standby Mode), clear BSY and return the interrupt immediately.

STANDBY IMMEDIATE (E0h)

This command causes the drive to set BSY, enter the Sleep mode (which corresponds to the ATA !Standby Mode), clear BSY and return the interrupt immediately.

WRITE DMA (CAh)

Write data to sectors during Ultra DMA and Multiword DMA transfer. Use the SET FEATURES command to specify the mode value.

WRITE MULTIPLE (C5h)

This command is similar to the Write Sectors command. Interrupts are not presented on each sector, but on the transfer of a block which contains the number of sectors defined by Set Multiple command.

WRITE SECTOR(S) (30h/31h)

Write data to a specified number of sectors (1 to 256, as specified with the Sector Count register) from the specified address. Specify "00h"– to write 256 sectors

H. Ordering Information

ADD:501#, Pioneering Park, University Town, LiShan Rd., Nanshan, Shenzhen, P.R. China

Tel:+86 0755-2698 5376 Fax:+86 0755-2698 5365

Website: www.kingspec.com



KSD-SA25.2-XXXMJ

KSD: Kingspec SSD
SA: SATA Interface
25: 2.5inch
.2: Revision 2.0
XXX: Density

XXX	Density
008	8GB
016	16GB
020	20GB
032	32GB
040	40GB
064	64GB
080	80GB
128	128GB
256	256GB

M: Based on MLC NAND Flash
J: SSD Controller is JMicron

